



technical specifications LR14/90



general

- RBN401 pro-ribbon HF driver with exceptional intelligibility and “throw”
- All Neodymium drivers for excellent performance-to-weight ratio
- SIS pre-wired for very high damping and further reduced distortion (with ALC)
- Maximum attainable “gain-before-feedback”
- Durotect™ scratch-resistant coating.
- Extended headroom/SPL and protection in combination with SDP circuit (in ALC)
- Passive filtering for easy operation and economical powering

description

The LR14 is a passive 2-way line-source loudspeaker system. It is a true line-array system, to be used as vertical array, either in stacked or flown configuration, for both portable and permanent installations. Loaded with the RBN401 ribbon driver on a “Morpher” lens (up to 94% frontal radiation!), the system features 90° dispersion with seamless coverage, due to the ribbon’s all-natural cylindrical (Isophasic) wavefront. Its transient response and unusual high peak power handling (800W/200mS) caters for an amazing intelligibility and throw, while offering maximum “gain-before-feedback” up to directly under the array.

The ultra-compact size, combined with the weight-saving all Neodymium drivers, makes the system very easy to handle.

The “Morpher” is mounted in the “ALrad™” waveguide, which utilizes the stiffness and heat transfer capabilities of aluminium. Mounted on the RBN, the ALrad™ extends the cooling surface for even further reducing power-compression for increased SPL over time.

The SignalIntegritySensing™ pre-wiring ensures complete cable/connector compensation between the LR14 and ALC. Typical (short to medium throw) applications for the LR14 include as compact main system for theatre and A/V or as under-fill in a LR16 system. It is available in 90° and 120° configuration.

The system includes dedicated filtering, but system equalizing is done remotely (electronically) fully utilizing the individual speaker components' power capacity. This results in increased headroom SPL.

In applications where extended bass response is required, the LR14 can be combined with a pressure-bass (LR14B) or deep-sub system (BF181), or both.

For full system performance, the LR14 needs to be driven by an ALC controller-amplifier. Driven by the ALC, the LR14 delivers maximum sound quality with inaudible (power and excursion) protection (SDP circuit).

More system application information can be found on www.theribbonnetwork.net

dimensional drawing

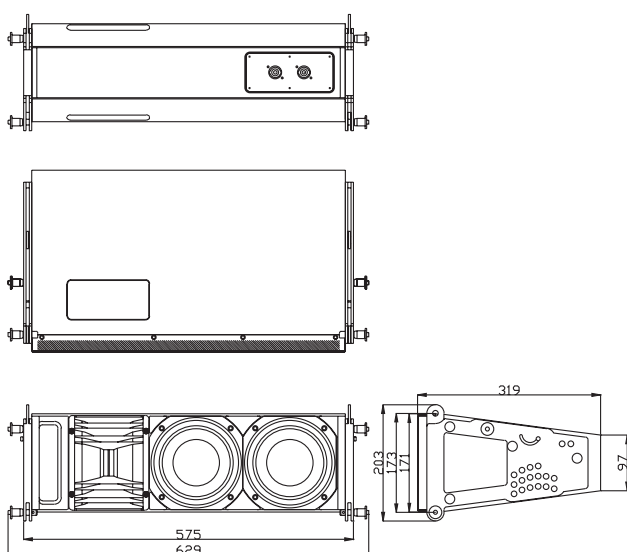

technical specifications

Frequency Response	
+/- 3 dB	74 Hz - 20.000 Hz
+/- 10 dB	53 Hz -
Sensitivity (SPL 1W/M)	95 dB
Sensitivity (nominal)	97 dB (200Hz. - 10kHz.)
Nominal Impedance	8 ohms
Maximum RMS power	400 W
Maximum peak power	1000 W
SPL program/peak (nom.)	123/131 dB
Dispersion H x V (array)	90° x depending on array length
Dispersion H x V (single)	90° x 15°

physical specifications

System	2-way, full-range	
Filtering	passive	
Drivers LF	2 x AND6.5/16 6.5", vented	
Driver HF	1 x RBN401 4" pro ribbon driver	
Cross-over frequency	1000 Hz.	
Connectors	2 x Speakon NL4 input / link	
Physical dimensions	mm	inches
Height	171/97	6,7/3,8
Width	575	22,6
Depth	319	12,6
Weight (approx.)	15 kg	(33,1 lb)
Warranty	6 years limited	

A: Alcons Audio B.V.
De Corantijn 69
1689 AN Zwaag
The Netherlands

E: info@alconsaudio.com
W: www.alconsaudio.com
T: +31 (0)229 28 30 90
F: +31 (0)229 28 30 99